



Oil Lubrication Stern Shaft Seal

- [Oil Lubrication Stern Shaft Seal](#)
- [How Oil Lubrication Stern Shaft Seal Work](#)
- [ABOUT OUR SEALS](#)
- [Technical parameters:](#)

Oil Lubrication Stern Shaft Seal

Marine Oil-lubricated seals are used most often for sealing rotary [shaft](#) applications. Oil-lubricated systems are the most common, but ship owners occasionally use water-lubricated and grease-lubricated systems.

Oil-lubricated seals are used most often for sealing rotary shaft applications. Oil-lubricated systems are the most common, but ship owners occasionally use water-lubricated and grease-lubricated systems.

How Oil Lubrication Stern Shaft Seal Work

The oil-lubricated Supreme seals close the gap between stationary and moving components of rotating shafts. It prevents the escape of lubricants (oil leakage) and the ingress of harmful materials such as dirt or sand. The lube oil system circulates the oil and controls pressure, flow and temperature in order to build up an appropriate lubrication film for the white metal slide bearing.

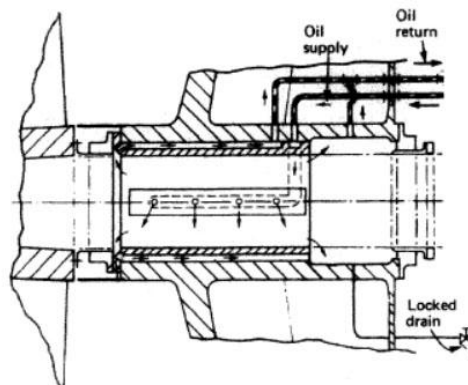

Oil lubricated sterntube bearing



ABOUT OUR SEALS



We believe that Oil Lubrication Stern Shaft Seal should provide the best performance to keep you going and give you peace of mind.

Our oil-lubricated shaft seals are used in tailpipes, thrusters, bulkheads, stabilizers, rudder stocks and gearboxes. Oil seals are produced with high-quality housing parts, rubber lip seals, and gaskets.

Technical parameters:

Diameter range of stern shaft: $\varnothing 50\text{-}\varnothing 1150\text{mm}$

Outer diameter of stern shaft wear-resisting bush: $\varnothing 70\text{-}\varnothing 1250\text{mm}$

Lubricating oil working pressure: 1-2bar

Lubricating oil working temperature: $-25^{\circ}\text{C}\text{-}+110^{\circ}\text{C}$

Stern shaft wear-resisting bush liner velocity: $\leq 7\text{m/sec}$

Average leakage: 5-30ml/h

Noah Marine Services (China)

Tingting: +86 159-6706-1188

sales@noah-marineservices.com

Peter Ye: +86 137-7774-8833

info@noah-marineservices.com

Sanqiao Industrial Zone, Oubei Town, Yongjia County, Wenzhou City, Zhejiang Province, China